



Manufacturer: -
BARTON FIRTOP ENGINEERING COMPANY LIMITED
 Stoke Heath Works, Hanbury Road.
 Bromsgrove. Worcestershire. B60 4LT.
 ENGLAND
 Telephone: (44) 01527 831644
 Fax: (44) 01527 832638
 E-mail: sales@bartonfirtop.co.uk

Data Sheet Number:
SDD/YCP/PN16/STL
 Revision: **05**

R/F – PN16 RATING CAST COMPACT 'Y'-TYPE STRAINER

Sizes: ½" to 12" Nominal Bore (DN15-300)

Pressure: PN16

- Features:**
- Integrally Cast Housing
 - Bolted Cover c/w Drain Plug
 - Compact / Lightweight Design
 - Perf. Screen (mesh lining to suit)

- Options:**
- Special Gasket, Special Screen
 - D.P. Tappings / Gauge
 - Magnetic Screen Insert
 - Flanged Drains / Drain Valves
 - Special Finish / Linings

Standards: PED 2014/68/EU
 BS EN 1092-1 Flange Dimensions
 EN 10204 / NACE Certification
 BS EN 558 (face-to-face)

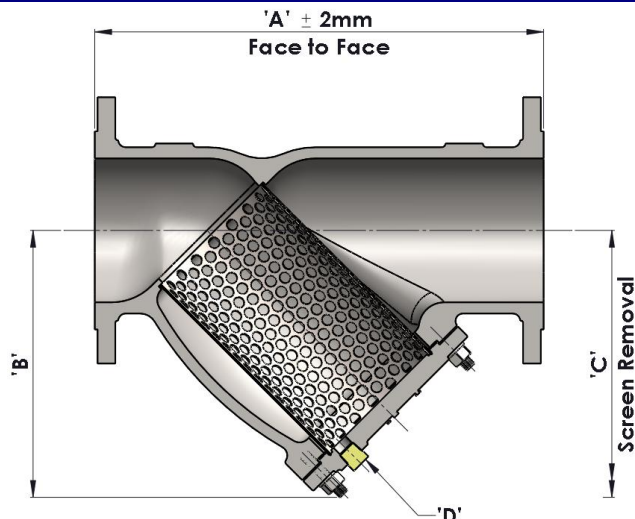

All data is subject to confirmation at the time of order. Our policy is one of continual improvement and we reserve the right to amend details without prior notice.

Size (NB)		Dimensions (mm)				Screen Area (cm ²)	Weight (kg) [C/S]
		'A' Face to Face	'B' Base to Centre line	'C' Screen Removal	'D' Drain (NPT)		
½"	15	130	80	125	¼"	30	2.5
¾"	20	150	93	145	¼"	46	3.6
1"	25	160	100	160	⅜"	59	4.5
1¼"	32	180	110	175	⅜"	92	6
1½"	40	200	120	190	⅜"	114	7
2"	50	230	152	230	½"	187	10.5
2½"	65	290	150	245	½"	238	13.5
3"	80	310	175	260	½"	355	18
4"	100	350	210	345	½"	575	25
5"	125	400	242	410	½"	885	38
6"	150	480	290	470	½"	1240	58
8"	200	600	370	590	¾"	2075	107
10"	250	730	475	740	¾"	3315	195
12"	300	850	560	870	¾"	4690	314

Materials of Construction		
Item	Carbon Steel	Stainless Steel
Strainer Body (Cast)	ASME SA216 WCB / DIN 1.0619**	ASME SA351 CF8M / DIN 1.4408
Strainer Cover (Cast)	ASME SA216 WCB / DIN 1.0619**	ASME SA351 CF8M / DIN 1.4408
Drain Plug (Forged)	ASME SA105N - Zinc Plated	ASME SA182 F316
Cover Studbolts	ASME SA193 B7M - Zinc Plated	ASME SA193 B8 / A2 (DIN 1.4301)
Cover Heavy Hex Nuts	ASME SA194 2HM - Zinc Plated	ASME SA194 Gr.8 / A2 (DIN 1.4301)
Cover Plain Washers	Carbon Steel – Zinc Plated	Stainless Steel 304
Cover Gasket (Flat)	C.N.A.F. as Standard / to Customer Specification	
Strainer Screen*	St. St. 316 (to Customer Specification)	

* Screens can be lined with mesh to suit Customer. ** Dual Certified Material - impact tested to -15°C.

Model Number Derivation: -

The model number can be derived as follows: - **A***/PN16/***/YCP**

Denotes the size i.e. add '025' for a 1" _____ '216' denotes Carbon Steel
 '351' denotes Stainless Steel

For more information, visit our Web Site: www.bartonfirtop.co.uk